

REVISION HISTORY			
REV.	DESCRIPTION	DATE	APPROVED
A	REDRAWN w/ CHANGE	09/22/2009	KAH
B	ECOR #A0144	09/22/2009	KAH
C	ECOR #A0448	09/22/2009	KAH
D	ECOR #A0954	05/16/2016	KAH

SECTION A-A

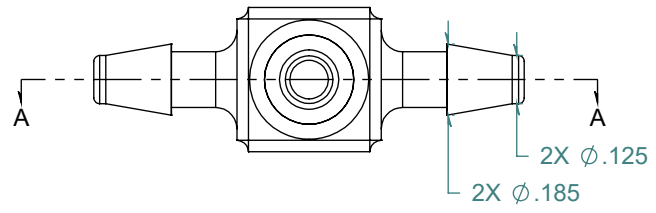

3X NO PARTING LINE ALLOWED ON THIS SURFACE

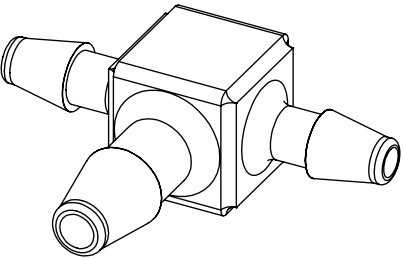
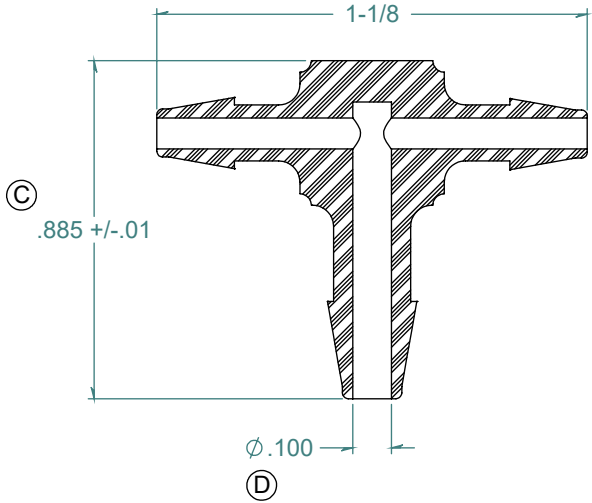
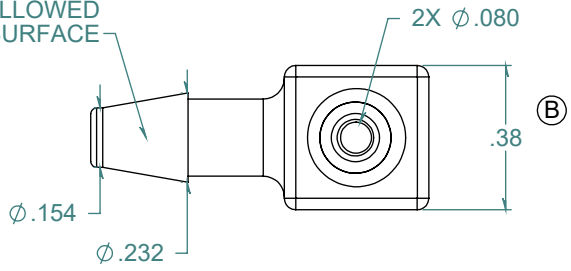

DIMENSIONS ARE IN INCHES UNLESS SPECIFIED. TOLERANCES ARE:  
 FRACTIONS +/- .015  
 2 PLACE DECIMAL +/- .010  
 3 PLACE DECIMAL +/- .005  
 ANGLES NOTED

**ARK-PLAS PRODUCTS, INC.**

MFD39-NY2  
 1/8 x 1/8 x 5/32 PREMIUMM GRADE  
 BARBED ENLARGING TEE CONNECTOR

MATERIAL:  
 NYLON, WHITE

FINISH:  
 RMS 109.2 / POLISHED BARBS

FREE SAMPLES ARE AVAILABLE FOR TESTING. CONTACT CUSTOMER SERVICE

**PROPRIETARY AND CONFIDENTIAL**  
 THE INFORMATION CONTAINED IN THIS DRAWING IS THE SOLE PROPERTY OF ARK-PLAS PRODUCTS, INC. ANY REPRODUCTION IN PART OR AS A WHOLE WITHOUT THE WRITTEN PERMISSION OF ARK-PLAS PRODUCTS, INC. IS PROHIBITED.

SIZE <b>A</b>	JOB # AP281	DRAWN BY: <i>KAH</i>	REV. LEVEL <b>D</b>
SCALE: 2:1 DO NOT SCALE DRAWING		SHEET 1 OF 1	