

REVISION HISTORY			
REV.	DESCRIPTION	DATE	APPROVED
A	REDRAWN w/o CHANGE	09/29/2009	KAH
B	ECOR #A0144	09/29/2009	KAH
C	ECOR #A0461	09/29/2009	KAH
D	ECOR #a0951	05/10/2016	KAH

SECTION A-A  
SCALE 2 : 1

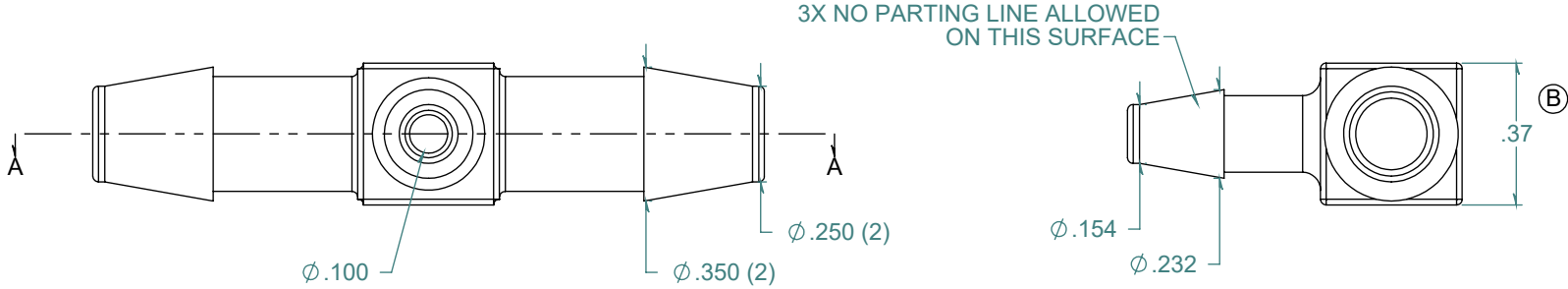
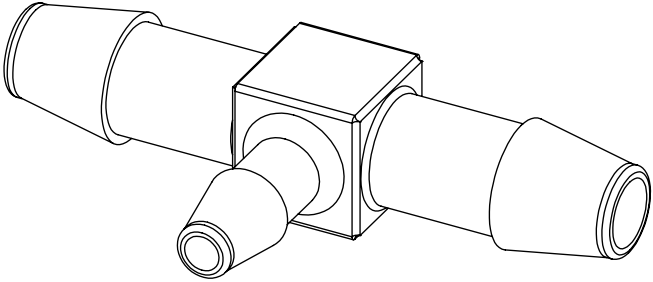
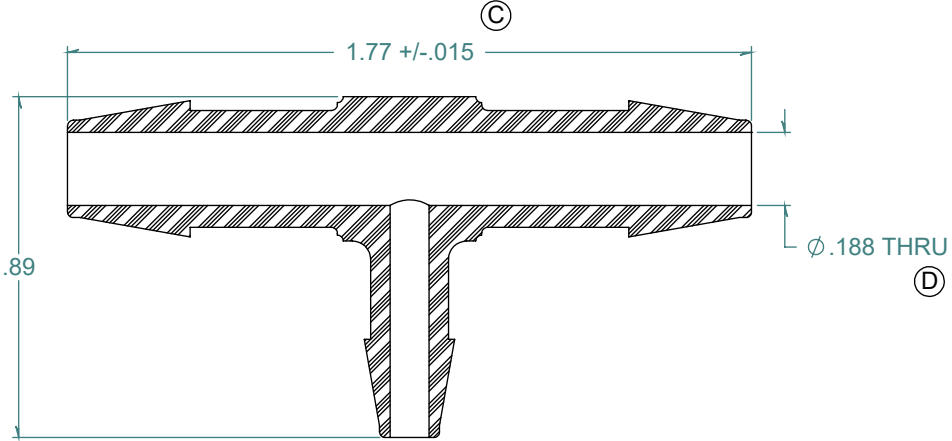

DIMENSIONS ARE IN INCHES UNLESS SPECIFIED. TOLERANCES ARE:  
 FRACTIONS +/- .015  
 2 PLACE DECIMAL +/- .010  
 3 PLACE DECIMAL +/- .005  
 ANGLES NOTED

**ARK-PLAS PRODUCTS, INC.**

MFC43-YC0  
 1/4 x 1/4 x 5/32 PREMIUM GRADE  
 BARBED REDUCING TEE CONNECTOR

FREE SAMPLES ARE AVAILABLE FOR TESTING. CONTACT CUSTOMER SERVICE

MATERIAL:  
 POLYCARBONATE, NATURAL

FINISH:  
 RMS 109.2 / POLISHED BARBS

SIZE	JOB # AP292A	DRAWN BY: <i>KAH</i>	REV. LEVEL
<b>A</b>	SCALE: 2:1 DO NOT SCALE DRAWING	SHEET 1 OF 1	<b>D</b>

**PROPRIETARY AND CONFIDENTIAL**  
 THE INFORMATION CONTAINED IN THIS DRAWING IS THE SOLE PROPERTY OF ARK-PLAS PRODUCTS, INC. ANY REPRODUCTION IN PART OR AS A WHOLE WITHOUT THE WRITTEN PERMISSION OF ARK-PLAS PRODUCTS, INC. IS PROHIBITED.