

REVISION HISTORY			
REV.	DESCRIPTION	DATE	APPROVED
A	REDRAWN w/ CHANGE	09/28/2009	KAH
B	ECOR #A0144	09/28/2009	KAH
C	ECOR #A0459	09/28/2009	KAH
D	ECOR #A0951	05/10/2016	KAH

SECTION A-A
SCALE 2 : 1

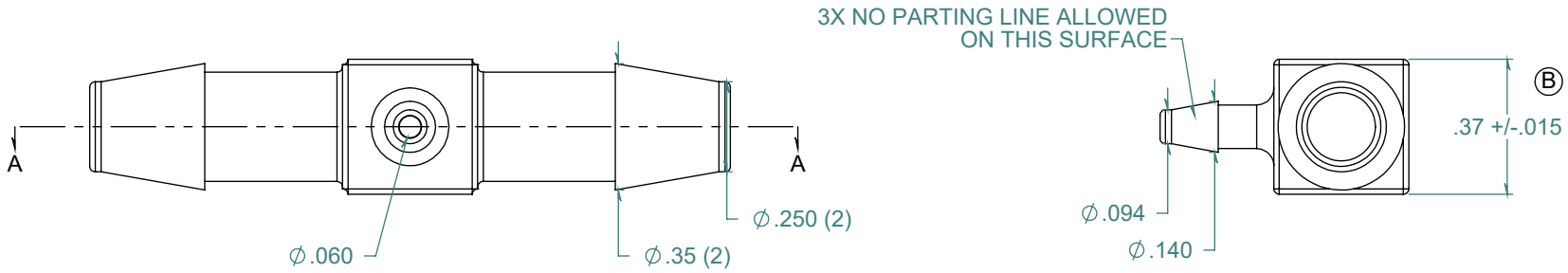
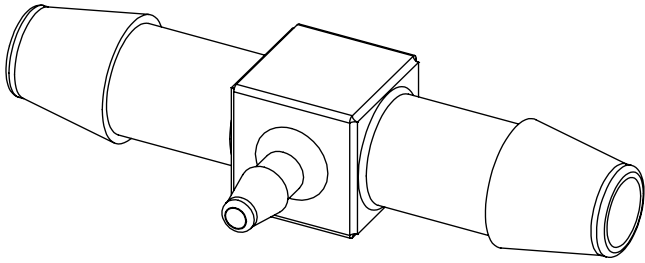
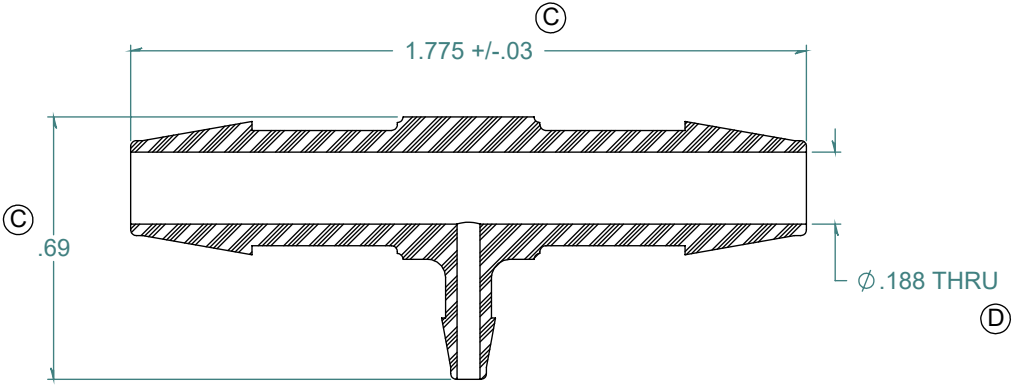

DIMENSIONS ARE IN INCHES UNLESS SPECIFIED. TOLERANCES ARE:
 FRACTIONS +/- .015
 2 PLACE DECIMAL +/- .010
 3 PLACE DECIMAL +/- .005
 ANGLES NOTED

ARK-PLAS PRODUCTS, INC.

MFC11-NY2
 1/4 x 1/4 x 3/32 PREMIUM GRADE
 BARBED REDUCING TEE CONNECTOR

FREE SAMPLES ARE AVAILABLE FOR TESTING. CONTACT CUSTOMER SERVICE

MATERIAL:
 NYLON, WHITE
 FINISH:
 RMS 109.2 / POLISHED BARBS

SIZE A	JOB # AP290A	DRAWN BY: <i>KAH</i>	REV. LEVEL D
SCALE: 2:1 DO NOT SCALE DRAWING		SHEET 1 OF 1	

PROPRIETARY AND CONFIDENTIAL
 THE INFORMATION CONTAINED IN THIS DRAWING IS THE SOLE PROPERTY OF ARK-PLAS PRODUCTS, INC. ANY REPRODUCTION IN PART OR AS A WHOLE WITHOUT THE WRITTEN PERMISSION OF ARK-PLAS PRODUCTS, INC. IS PROHIBITED.