

SECTION A-A  
SCALE 2 : 1

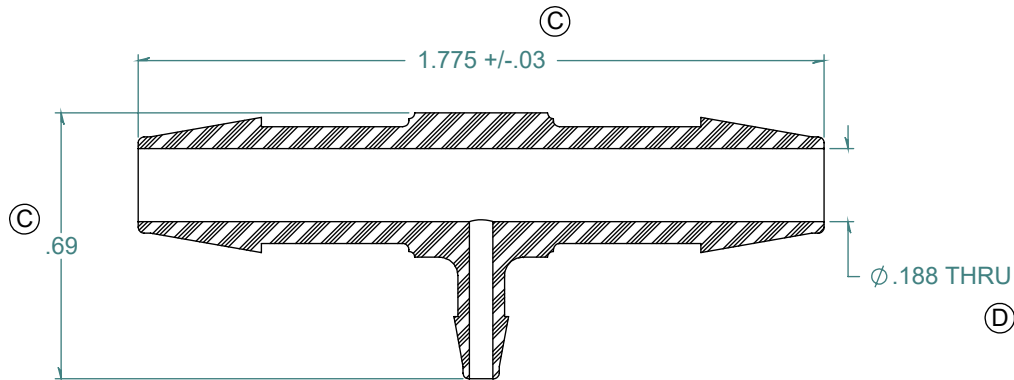

REVISION HISTORY			
REV.	DESCRIPTION	DATE	APPROVED
A	REDRAWN w/ CHANGE	09/28/2009	KAH
B	ECOR #A0144	09/28/2009	KAH
C	ECOR #A0459	09/28/2009	KAH
D	ECOR #A0951	05/10/2016	KAH

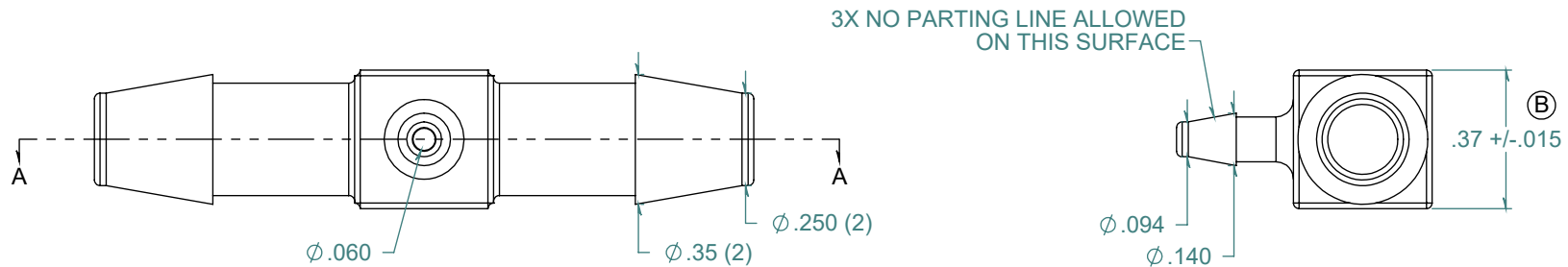
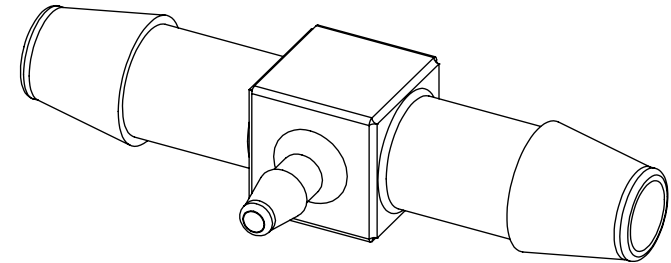

DIMENSIONS ARE IN INCHES UNLESS SPECIFIED. TOLERANCES ARE:  
 FRACTIONS +/- .015  
 2 PLACE DECIMAL +/- .010  
 3 PLACE DECIMAL +/- .005  
 ANGLES NOTED

**ARK-PLAS PRODUCTS, INC.**

MFC11-YC0  
 1/4 x 1/4 x 3/32 PREMIUM GRADE  
 BARBED REDUCING TEE CONNECTOR

FREE SAMPLES ARE AVAILABLE FOR TESTING. CONTACT CUSTOMER SERVICE

MATERIAL:  
 POLYCARBONATE, NATURAL

FINISH:  
 RMS 109.2 / POLISHED BARBS

SIZE <b>A</b>	JOB # AP290A	DRAWN BY: <i>KAH</i>	REV. LEVEL <b>D</b>
SCALE: 2:1 DO NOT SCALE DRAWING		SHEET 1 OF 1	

**PROPRIETARY AND CONFIDENTIAL**

THE INFORMATION CONTAINED IN THIS DRAWING IS THE SOLE PROPERTY OF ARK-PLAS PRODUCTS, INC. ANY REPRODUCTION IN PART OR AS A WHOLE WITHOUT THE WRITTEN PERMISSION OF ARK-PLAS PRODUCTS, INC. IS PROHIBITED.