

REVISION HISTORY			
REV.	DESCRIPTION	DATE	APPROVED
A	REDRAWN w/ CHANGE	09/28/2009	KAH
B	ECOR #A0144	09/28/2009	KAH
C	ECOR #A0456	09/28/2009	KAH
D	ECOR #A0951	05/10/2016	KAH

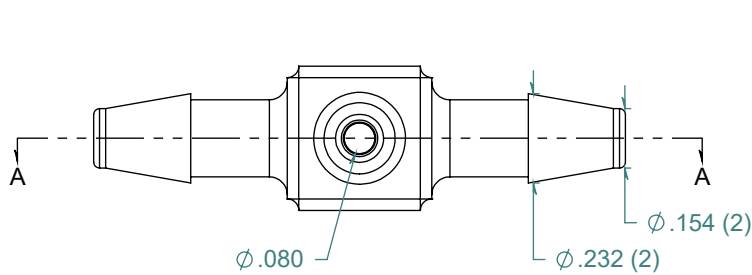

3X NO PARTING LINE ALLOWED ON THIS SURFACE

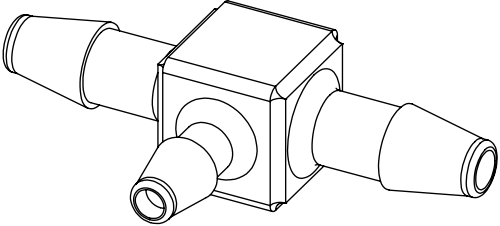
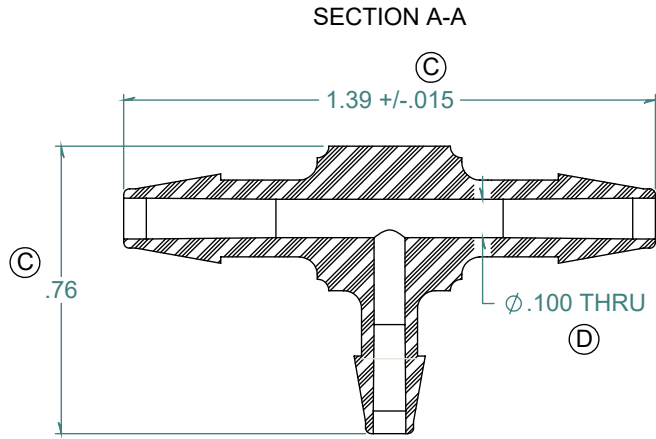
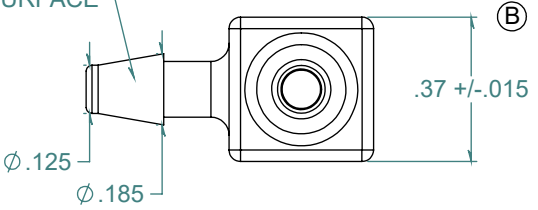

FREE SAMPLES ARE AVAILABLE FOR TESTING. CONTACT CUSTOMER SERVICE

DIMENSIONS ARE IN INCHES UNLESS SPECIFIED. TOLERANCES ARE:
 FRACTIONS +/- .015
 2 PLACE DECIMAL +/- .010
 3 PLACE DECIMAL +/- .005
 ANGLES NOTED

ARK-PLAS PRODUCTS, INC.

MFC63-YC0
 5/32 x 5/32 x 1/8 PREMIUM GRADE
 BARBED REDUCING TEE CONNECTOR

MATERIAL:
 POLYCARBONATE, NATURAL
 FINISH:
 RMS 109.2 / POLISHED BARBS

SIZE	JOB # AP286A	DRAWN BY: <i>KAH</i>	REV. LEVEL
A	SCALE: 2:1 DO NOT SCALE DRAWING	SHEET 1 OF 1	D

PROPRIETARY AND CONFIDENTIAL
 THE INFORMATION CONTAINED IN THIS DRAWING IS THE SOLE PROPERTY OF ARK-PLAS PRODUCTS, INC. ANY REPRODUCTION IN PART OR AS A WHOLE WITHOUT THE WRITTEN PERMISSION OF ARK-PLAS PRODUCTS, INC. IS PROHIBITED.