

REVISION HISTORY			
REV.	DESCRIPTION	DATE	APPROVED
A	PRINT RELEASE DATE	12/05/2013	KAH
B	ECOR #A0928	01/27/2016	KAH

SECTION A-A
SCALE 1 : 1

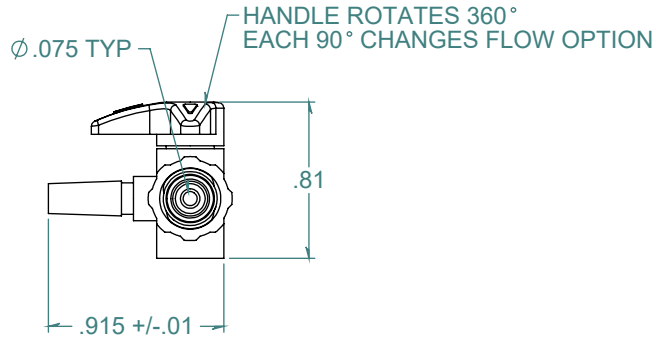
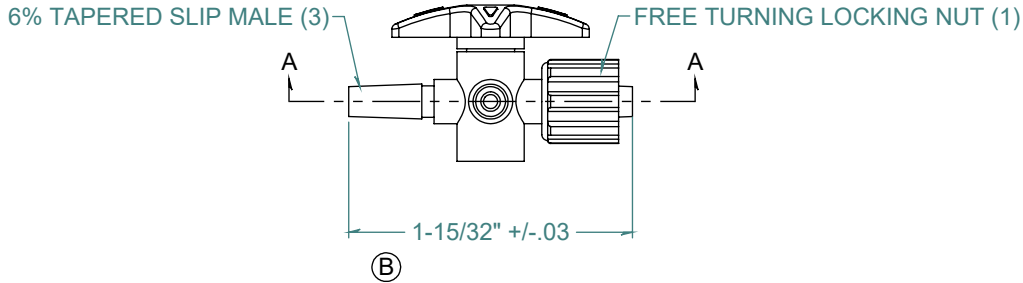
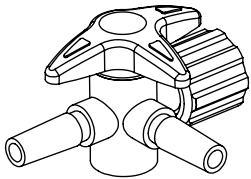
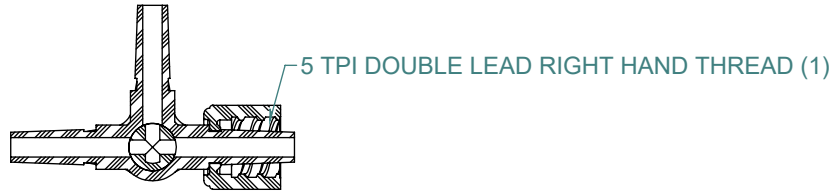

DIMENSIONS ARE IN INCHES UNLESS SPECIFIED. TOLERANCES ARE:
 FRACTIONS +/- .015
 2 PLACE DECIMAL +/- .010
 3 PLACE DECIMAL +/- .005
 ANGLE NOTED

ARK-PLAS PRODUCTS, INC.

RCX38-GP0
 LOCKING MALE x SLIP MALE x SLIP MALE
 4-WAY SMALL LUER STOPCOCK

MATERIAL: HD POLYETHYLENE - HANDLE
 RAD. STABILIZED POLYCARBONATE - BODY

LUERS DESIGNED TO ISO STANDARDS

FINISH:
 RMS 109.2 / POLISHED LUERS

SIZE	JOB # AP353	DRAWN BY: KAH	REV. LEVEL
A	SCALE: 1:1 DO NOT SCALE DRAWING	SHEET 1 OF 1	B

FREE SAMPLES ARE AVAILABLE FOR TESTING. CONTACT CUSTOMER SERVICE

PROPRIETARY AND CONFIDENTIAL

THE INFORMATION CONTAINED IN THIS DRAWING IS THE SOLE PROPERTY OF ARK-PLAS PRODUCTS, INC. ANY REPRODUCTION IN PART OR AS A WHOLE WITHOUT THE WRITTEN PERMISSION OF ARK-PLAS PRODUCTS, INC. IS PROHIBITED.