

REVISION HISTORY			
REV.	DESCRIPTION	DATE	APPROVED
A	REDRAWN w/ CHANGE	09/22/2009	KAH
B	ECOR #A0144	09/22/2009	KAH
C	ECOR #A0450	09/22/2009	KAH
D	ECOR #A0954	05/16/2016	KAH
E	ECO #A1147	07/23/2018	KAH

SECTION A-A
SCALE 1 : 1

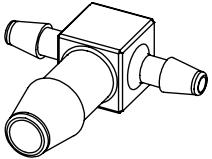

3X NO PARTING LINE ALLOWED
ON THIS SURFACE

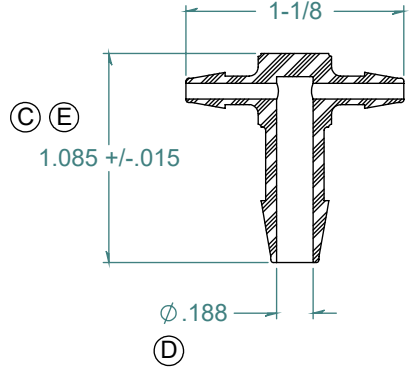
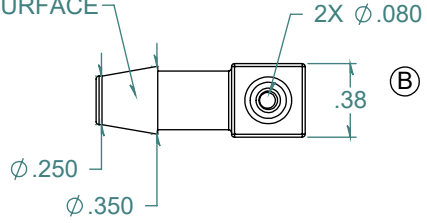
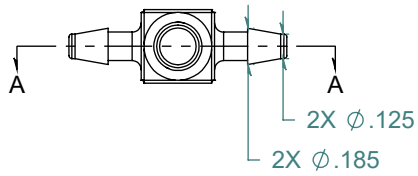

DIMENSIONS ARE IN INCHES UNLESS SPECIFIED. TOLERANCES ARE:
 FRACTIONS +/- .015
 2 PLACE DECIMAL +/- .010
 3 PLACE DECIMAL +/- .005
 ANGLES NOTED

ARK-PLAS PRODUCTS, INC.

MFD74-YC0
 1/8 x 1/8 x 1/4 PREMIUM GRADE
 BARBED ENLARGING TEE CONNECTOR

MATERIAL:
 POLYCARBONATE, NATURAL
 FINISH:
 RMS 109.2 / POLISHED BARBS

SIZE A	JOB # AP283A	DRAWN BY: <i>KAH</i>	REV. LEVEL E
SCALE: 2:1 DO NOT SCALE DRAWING		SHEET 1 OF 1	

FREE SAMPLES ARE AVAILABLE FOR TESTING. CONTACT CUSTOMER SERVICE

PROPRIETARY AND CONFIDENTIAL

THE INFORMATION CONTAINED IN THIS DRAWING IS THE SOLE PROPERTY OF ARK-PLAS PRODUCTS, INC. ANY REPRODUCTION IN PART OR AS A WHOLE WITHOUT THE WRITTEN PERMISSION OF ARK-PLAS PRODUCTS, INC. IS PROHIBITED.