

SECTION A-A

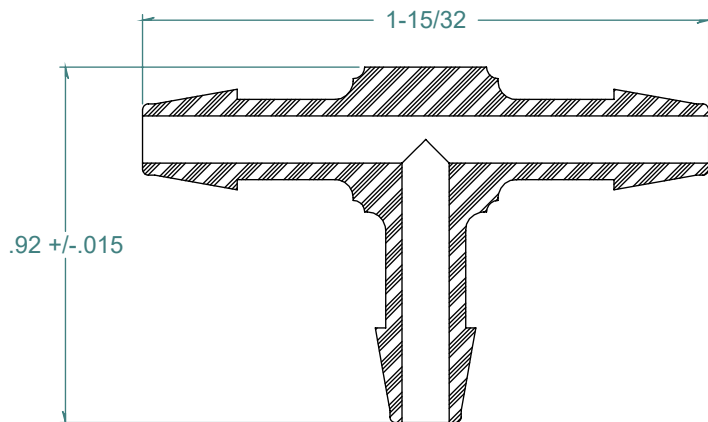

REVISION HISTORY			
REV.	DESCRIPTION	DATE	APPROVED
A	REDRAWN w/o CHANGE	09/04/2009	KAH

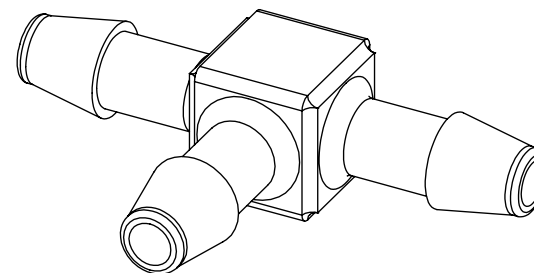

3X NO PARTING LINE ALLOWED ON THIS SURFACE

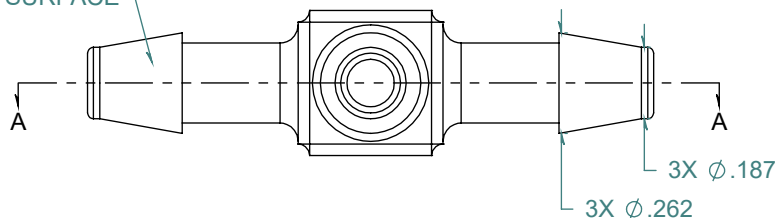

Ø.120 TYP

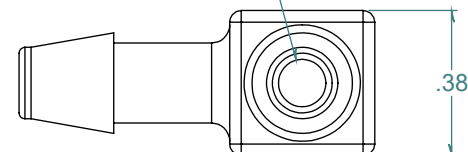

DIMENSIONS ARE IN INCHES UNLESS SPECIFIED. TOLERANCES ARE:
 FRACTIONS +/- .015
 2 PLACE DECIMAL +/- .010
 3 PLACE DECIMAL +/- .005
 ANGLES NOTED

ARK-PLAS PRODUCTS, INC.

MFA31-NY2
 3/16 x 3/16 x 3/16 PREMIUM GRADE
 BARBED TEE CONNECTOR

FREE SAMPLES ARE AVAILABLE FOR TESTING. CONTACT CUSTOMER SERVICE

MATERIAL:
 NYLON, WHITE

FINISH:
 RMS 109.2 / POLISHED BARBS

SIZE	JOB # AP274A	DRAWN BY: KAH	REV. LEVEL
A	SCALE: 2:1 DO NOT SCALE DRAWING	SHEET 1 OF 1	A

PROPRIETARY AND CONFIDENTIAL
 THE INFORMATION CONTAINED IN THIS DRAWING IS THE SOLE PROPERTY OF ARK-PLAS PRODUCTS, INC. ANY REPRODUCTION IN PART OR AS A WHOLE WITHOUT THE WRITTEN PERMISSION OF ARK-PLAS PRODUCTS, INC. IS PROHIBITED.