

REVISION HISTORY			
REV.	DESCRIPTION	DATE	APPROVED
A	REDRAWN w/ CHANGE	03/18/2010	KAH
B	ECOR #A0592	03/18/2010	KAH
C	ECOR #A0836	01/08/2014	KAH
D	ECOR #A0899	10/14/2015	KAH
E	ECOR #A0924	01/19/2016	KAH
F	ECOR #A1059	10/25/2017	KAH

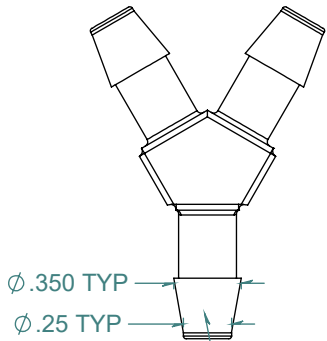

Ⓔ

3X NO PARTING LINE ALLOWED ON THIS SURFACE

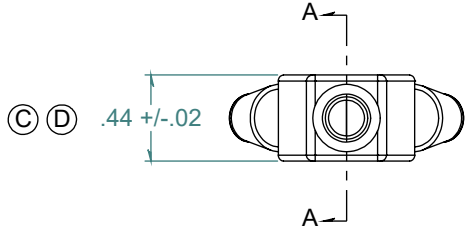
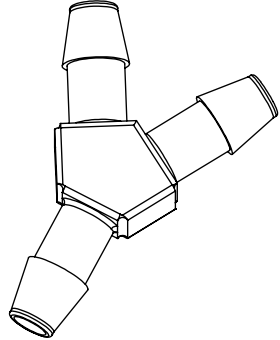

Ⓒ Ⓓ

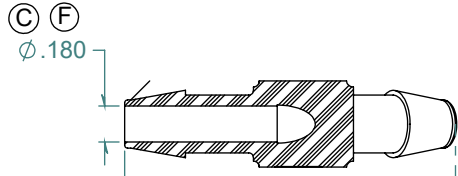

Ⓒ Ⓕ

Ⓑ Ⓖ

SECTION A-A

DIMENSIONS ARE IN INCHES UNLESS SPECIFIED. TOLERANCES ARE:
 FRACTIONS +/- .015
 2 PLACE DECIMAL +/- .010
 3 PLACE DECIMAL +/- .005
 ANGLES NOTED

ARK-PLAS PRODUCTS, INC.

MDX71-DF0
 1/4 x 1/4 x 1/4 PREMIUM GRADE
 BARBED Y CONNECTOR

MATERIAL:
 KYNAR, NATURAL

FINISH:
 RMS 109.2 / POLISHED BARBS

SIZE A	JOB # AP035A	DRAWN BY: <i>KAH</i>	REV. LEVEL F
SCALE: 1:1 DO NOT SCALE DRAWING		SHEET 1 OF 1	

FREE SAMPLES ARE AVAILABLE FOR TESTING. CONTACT CUSTOMER SERVICE

PROPRIETARY AND CONFIDENTIAL

THE INFORMATION CONTAINED IN THIS DRAWING IS THE SOLE PROPERTY OF ARK-PLAS PRODUCTS, INC. ANY REPRODUCTION IN PART OR AS A WHOLE WITHOUT THE WRITTEN PERMISSION OF ARK-PLAS PRODUCTS, INC. IS PROHIBITED.