

5

4

3

2

1

SECTION A-A
SCALE 3 : 1

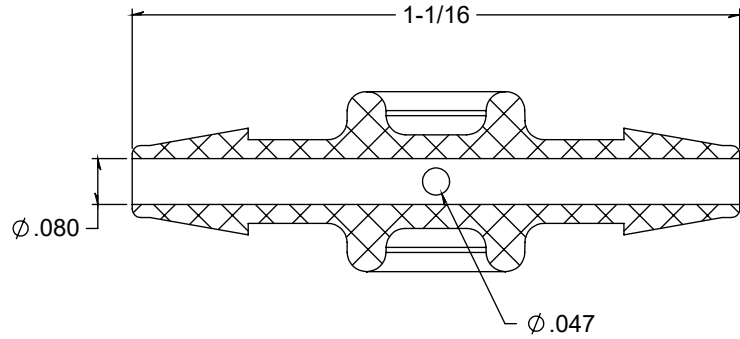

REVISIONS			
REV.	DESCRIPTION	DATE	APPROVED
A	REDRAWN w/CHANGE	09/24/2009	KAH
B	ECOR#A0453	09/24/2009	KAH
C	ECOR#A0951	05/10/2016	KAH
D	ECOR#A0954	05/16/2016	KAH
E	New Body Style	01/11/2022	JWM

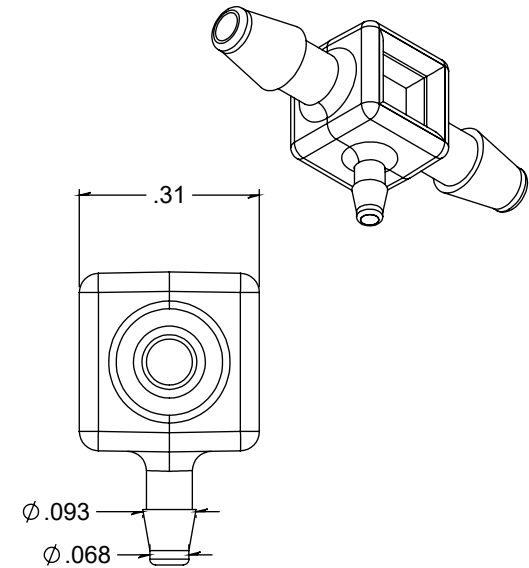
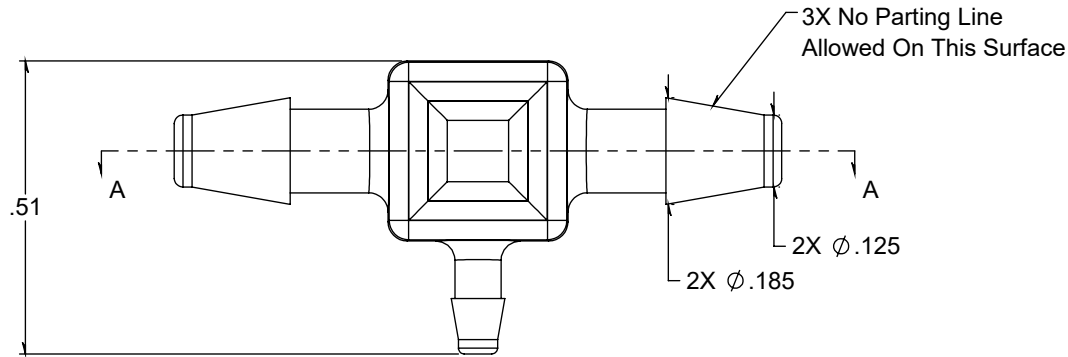

DIMENSIONS ARE IN INCHES
UNLESS SPECIFIED.
TOLERANCES ARE:

FRACTIONS	+/- .015
2 PLACE DECIMAL	+/- .010
3 PLACE DECIMAL	+/- .005
4 PLACE DECIMAL	+/- .0005
ANGLES	+/- 1/2°

MATERIAL:
Polycarbonate, Natural

FINISH:
RMS 109.2

ARK-PLAS PRODUCTS, INC.

MFC26-YC0
1/8 x 1/8 x 1/16 Premium Grade
Barb Reducing Tee Connector

PROPRIETARY AND CONFIDENTIAL
THE INFORMATION CONTAINED IN THIS DRAWING IS THE SOLE PROPERTY OF
ARK-PLAS PRODUCTS, INC. ANY REPRODUCTION IN PART OR AS A WHOLE
WITHOUT THE WRITTEN PERMISSION OF ARK-PLAS PRODUCTS, INC. IS PROHIBITED.

SIZE	JOB #	DRAWN BY:	REV. LEVEL
A	MFC26	JWM	E
	SCALE: 3:1	SHEET 1 OF 1	

5

4

3

2

1