

REVISION HISTORY			
REV.	DESCRIPTION	DATE	APPROVED
A	REDRAWN w/ CHANGE	10/05/2009	KAH
B	ECOR #A0144	10/05/2009	KAH
C	ECOR #A0474	10/05/2009	KAH

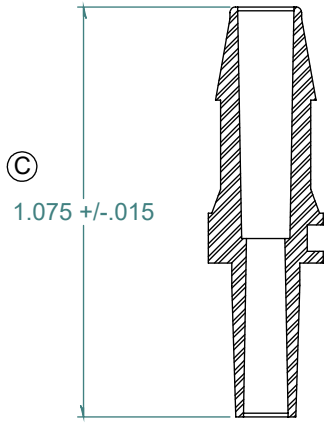

SECTION A-A

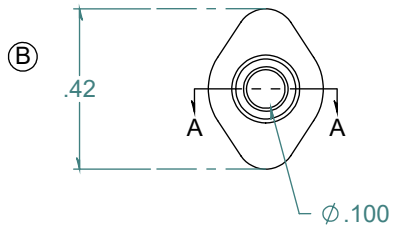
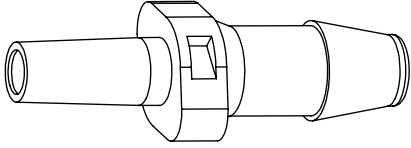

NO PARTING LINE ALLOWED ON THIS SURFACE
6% TAPERED SLIP MALE

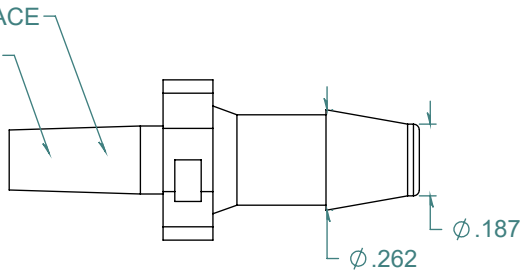

DIMENSIONS ARE IN INCHES UNLESS SPECIFIED. TOLERANCES ARE:
 FRACTIONS +/- .015
 2 PLACE DECIMAL +/- .010
 3 PLACE DECIMAL +/- .005
 ANGLE +/- 1/2°

ARK-PLAS PRODUCTS, INC.

LCX26-NY0
3/16 MALE SLIP LUER

MATERIAL: NYLON, NATURAL

LUER DESIGNED TO **ISO** STANDARDS

FINISH: RMS 109.2
POLISHED LUER

SIZE A	JOB # AP731	DRAWN BY: <i>KAH</i>	REV. LEVEL C
SCALE: 2:1 DO NOT SCALE DRAWING		SHEET 1 OF 1	

FREE SAMPLES ARE AVAILABLE FOR TESTING. CONTACT CUSTOMER SERVICE

PROPRIETARY AND CONFIDENTIAL

THE INFORMATION CONTAINED IN THIS DRAWING IS THE SOLE PROPERTY OF ARK-PLAS PRODUCTS, INC. ANY REPRODUCTION IN PART OR AS A WHOLE WITHOUT THE WRITTEN PERMISSION OF ARK-PLAS PRODUCTS, INC. IS PROHIBITED.