

REVISION HISTORY			
REV.	DESCRIPTION	DATE	APPROVED
A	REDRAWN w/ CHANGE	02/10/2010	KAH
B	ECOR #A0557	02/10/2010	KAH
C	ECOR #A0955	01/18/2018	KAH

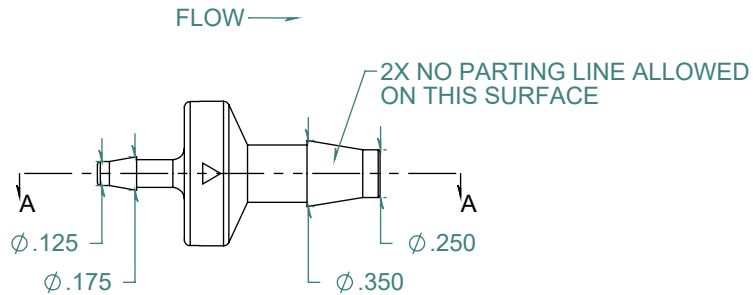
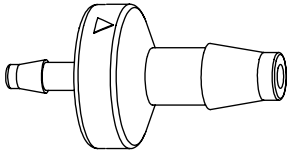
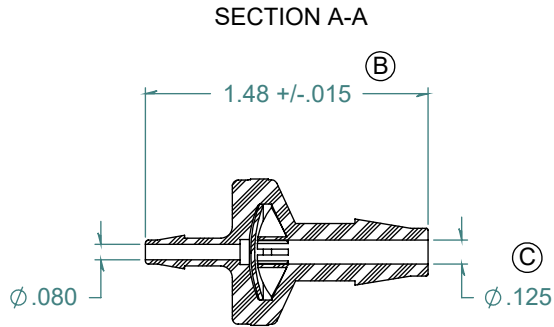

DIMENSIONS ARE IN INCHES UNLESS SPECIFIED. TOLERANCES ARE:
 FRACTIONS +/- .015
 2 PLACE DECIMAL +/- .010
 3 PLACE DECIMAL +/- .005
 ANGLES NOTED

ARK-PLAS PRODUCTS, INC.

HDX44-DF0
 1/8 x 1/4 ENLARGING CHECK VALVE

FREE SAMPLES ARE AVAILABLE FOR TESTING. CONTACT CUSTOMER SERVICE

MATERIAL:
 KYNAR, NATURAL

FINISH:
 RMS 109.2 / POLISHED BARBS

SIZE	JOB #	DRAWN BY:	REV. LEVEL
A	MP137	KAH	C
	MP146		
SCALE: 1:1 DO NOT SCALE DRAWING		SHEET 1 OF 1	

PROPRIETARY AND CONFIDENTIAL
 THE INFORMATION CONTAINED IN THIS DRAWING IS THE SOLE PROPERTY OF ARK-PLAS PRODUCTS, INC. ANY REPRODUCTION IN PART OR AS A WHOLE WITHOUT THE WRITTEN PERMISSION OF ARK-PLAS PRODUCTS, INC. IS PROHIBITED.