

Revision History

Rev.	Description	Date	Approved
A	Redrawn w/o Change	09/04/2009	KAH
B	ECOR #A0144	09/04/2009	KAH
C	ECOR #A0819	07/24/2013	KAH
D	Body Updated	10/17/2023	JWM

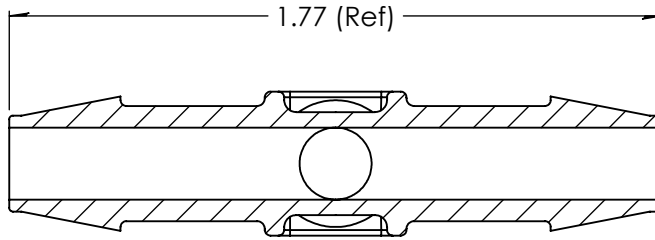

SECTION A-A
SCALE 2 : 1

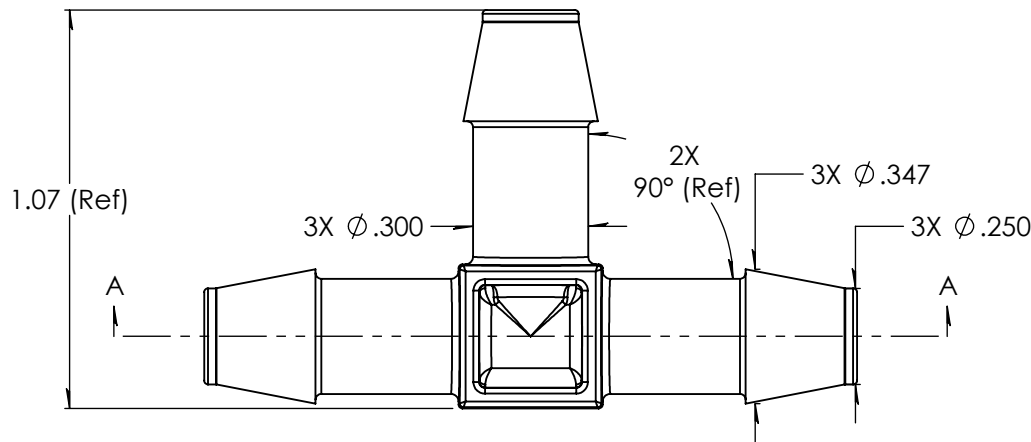

3X No parting line allowed
on this surface

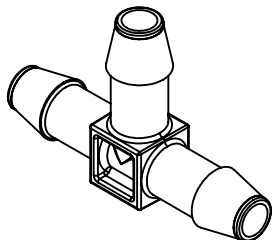
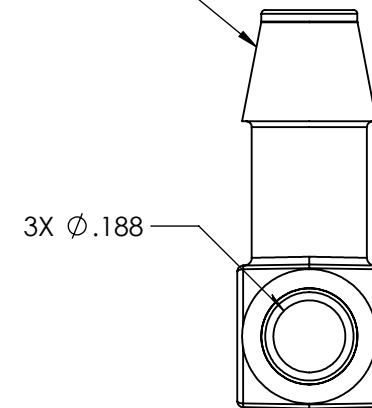

Unless otherwise specified tolerances are in inches

SAE Tolerances

Fractions:	+/- .015
2 Place Decimal:	+/- .010
3 Place Decimal:	+/- .005
Angle:	+/- 1/2*

Material:

White Nylon
101FNC010

ARKPLAS

Part #: MFA60-NY2

Description:
1/4" x 1/4" x 1/4" Premium Grade Barbed Tee
Connector

Size	Job#:	Sheet	Rev
A	MFA60	1 of 1	D
	Scale: 2:1	Drawn By: JWM	