

Revision History

Rev.	Description	Date	Approved
A	Print release date	02/17/2010	KAH
B	ECOR #A0572	02/17/2010	KAH
C	ECO #A1225	05/20/2020	KAH
D	ECO	04/07/2023	JWM

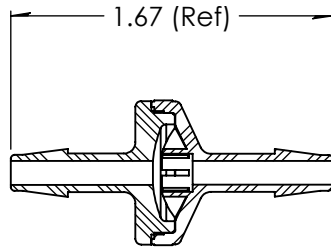

SECTION A-A

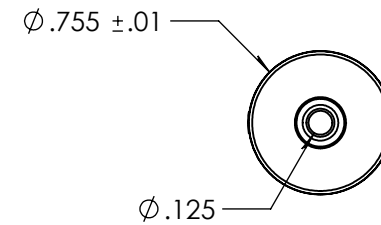
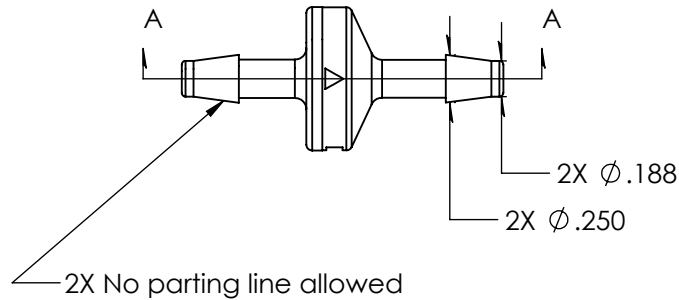
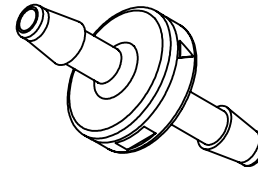

Unless otherwise specified tolerances are in inches

SAE Tolerances

Fractions:	+/- .015
2 Place Decimal:	+/- .010
3 Place Decimal:	+/- .005
Angle:	+/- 1/2*

Material:

Natural Polycarbonate
201-15



Part #: HAX14-YC0

Description:
3/16" X 3/16" Standard Check Valve
Viton Diaphragm

Size A	Job#: HAX14	Sheet 1 of 1	Rev D
	Scale: 1:1	Drawn By: JWM	